

# Z2-N

TTL Li-ion Camera Flash

Instruction Manual

### Copyright

© 2023 Shenzhen NEEWER Technology Co., Ltd. All Rights Reserved. This document is the sole property of Shenzhen NEEWER Technology Co., Ltd and shall not be reproduced, transmitted, transcribed, stored in a retrieval system or translated in any form, by any means, without prior written permission from Shenzhen NEEWER Technology Co., Ltd. Shenzhen NEEWER Technology Co., Ltd reserves the right to change content in this instruction manual at any time and without prior notice.

### Version Control

Date	Version number	Description	Issued by
06/29/2023	1.0	TTL Li-ion Camera Flash Manual	NEEWER®

### Catalog

Foreword	02
Precautions	02
Package Contents	03
Name of components	03
Battery	06
Power Management	07
Mount / Unmount flash	08
Flash Mode: i-TTL Autoflash	08
1. i-TTL Mode	
2. FEC(Flash Exposure Compensation)	
3. HSS: High Speed Sync	
4. Second-Curtain Sync	
M: Manual Flash	11
RPT: Stroboscopic Flash	12
Wireless Flash Shooting: Wireless (2.4G) Transmission	13
1. Wireless Settings	
2. Flash Group Mode Selection	
3. Setting the communication channel	
4. Wireless ID Settings	
5. Scan for a free, unused channel	
6. i-TTL: Automatic wireless flash photography	
7. M: Manual Wireless Flash Shooting	
8. RPT: Wireless Flash Shooting with Manual Flash	
Wireless Flash Shooting: Wireless (2.4G) Transmission	21
Other Applications	21
1. Sync Triggering	
2. Auto Focus Assist Beam	
3. TCM - One key switching i-TTL/M mode	
4. Bounce Flash	
5. ZOOM: Set the flash coverage	
6. Modeling Lamp	
7. Modeling Flash	
C.Fn: Setting Custom Functions	23
Protection Function	25
Technical Data	26
Troubleshooting	27
Firmware upgrade	28
Restore factory settings	28
Compatible Cameras	28

### Foreword

Thank you for your purchase of a **NEEWER®** product. Z2-N is a i-TTL speedlite flash designed for Nikon cameras. With i-TTL auto flash, you will automatically get the accurate amount of flash exposure for variable lighting conditions, thereby improving your overall shooting experience. The following features set it apart from the competition:

- Maximum flash power of 76Ws, 81 levels of dimming (1/1-1/256)
- 3000mAh Li-polymer battery with an autonomy of 600 flashes at full power, 1.5 seconds fast recharge.
- Supports i-TTL auto flash, which can be used as the master or slave unit of a wireless multi-lamp flash system - making shooting easier and faster.
- LCD screen for an intuitive display and easy operation.
- Built-in 2.4GHz wireless transmission, integrated transmitter and receiver with a large radius.
- Supports manual frequency flash mode, HSS/second curtain sync /FEC and other i-TTL functions.
- Stable output, High speed continuous flash and color temperature with good even lighting.
- Firmware will be upgraded as the camera is updated.

### Precautions

1. Always keep this product dry.
2. Keep this product out of reach of children.
3. Do not disassemble or modify the product.
4. Do not subject to any form of physical shock. The product shouldn't be exposed to fire or an environment where the temperature exceeds 50 degrees.
5. Do not fire the flash directly into the eyes which could result in visual impairment.
6. Do not use the product near chemicals, flammable gases or other volatile substances which may cause fire or electromagnetic interference.
7. Do not use in the rain or in damp conditions.
8. Turn off the product immediately, if it appears to be operating abnormally, and try to troubleshoot the likely cause.
9. Failure to comply with the recommendations and warnings listed in the manual will invalidate the warranty.

### Package Contents



### Name of components

#### 1. Flash Body

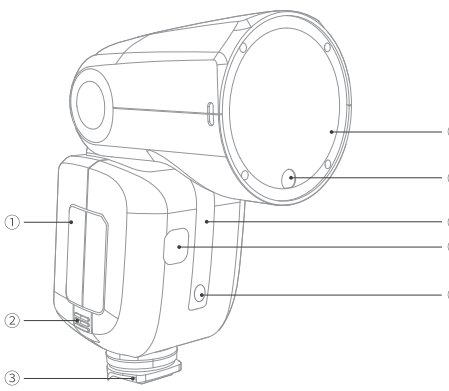

1. Lithium Battery
2. Battery Release Button
3. Hot Shoe Base
4. Flash Head
5. Wireless Sensor
6. Modeling Lamp
7. Focus Assist Lamp

### Name of components

#### 2. Control Panel

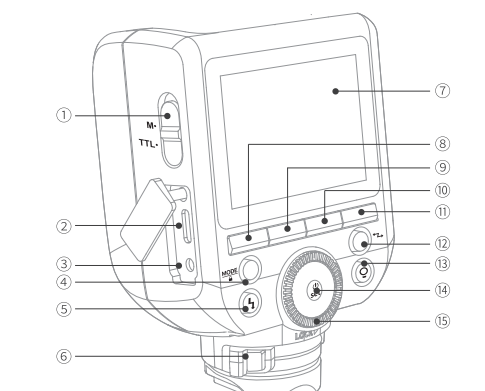

1. <TCM> One-touch Switching
2. Type-C USB Upgrade Port
3. Sync Jack
4. <MODE> Mode Selection/ Lock Button
5. <F> Test Flash Button/ Recycling Indicator
6. Hot Shoe Fixing Button
7. Display
8. Function Button 1
9. Function Button 2
10. Function Button 3
11. Function Button 4
12. <L> <R> Wireless Button
13. <M> <A> Modeling Lamp
14. Power ON-OFF/Setting Button
15. Adjustment Knob

\* The USB Type-C port is exclusively intended for flash firmware upgrades and is not designed for charging purposes.

#### 3. LCD Panel

##### (1) i-TTL Autoflash

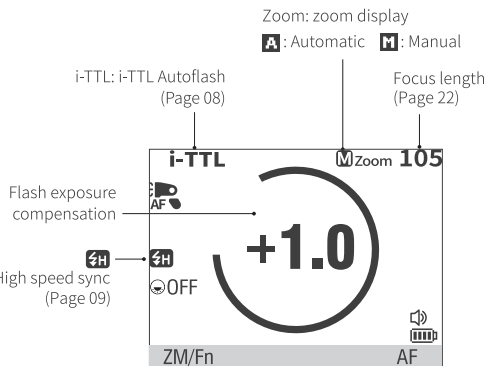

### Name of components

#### (2) M Manual Flash(Page 11)

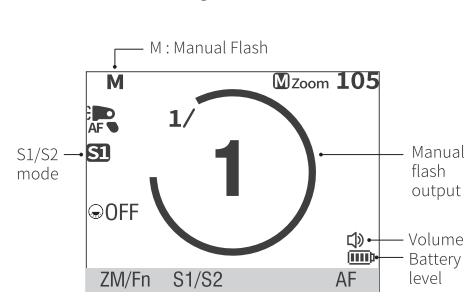

#### (3) RPT Flash(Page 12)

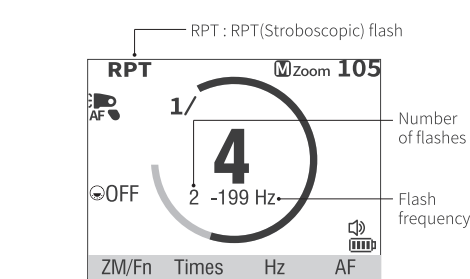

#### (4) Wireless Transmission Shooting(Page 13)

##### ① Transmitter Unit

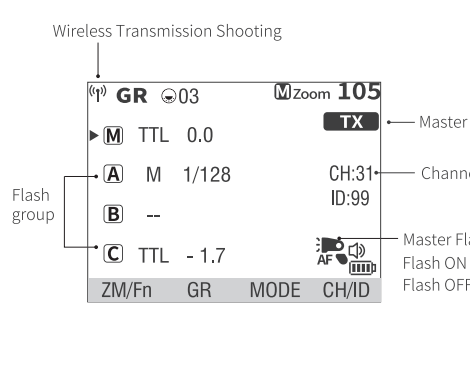

### Name of components

#### ② RX unit

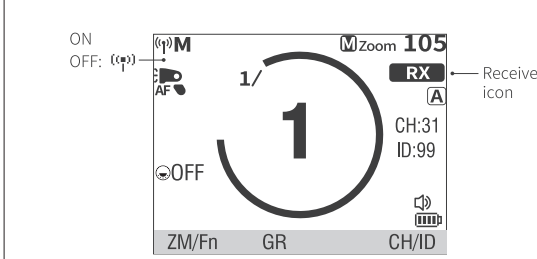

### Battery

#### 1. Features

- ① This flash unit uses Li-ion polymer battery which boasts a long service life and can be charged / discharged up to 500 times.
- ② Safe and reliable, the built-in circuit protects against overcharge, overdischarge, overcurrent, and short circuit.

#### 2. Caution

- ① Do not short circuit.
- ② Do not immerse the battery in water.
- ③ Keep the battery out of reach of children.
- ④ Do not exceed 24 hours of continuous charging.
- ⑤ Store the battery in a dry, cool and ventilated environment.
- ⑥ Do not place the battery near or in a fire.
- ⑦ Dead batteries should be disposed according to local regulations.
- ⑧ If the battery isn't to be used for some time, please ensure it is charged at least every 3 months.

#### 3. Inserting and Removing the Battery

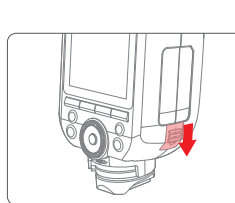

- ③ Removing the battery  
Slide the button in the direction shown to remove the battery.

### Battery

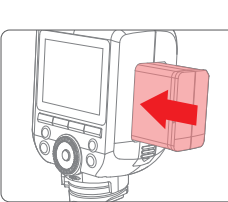

- ② Inserting the battery  
Insert the lithium battery into the battery compartment in the direction indicated by the battery until the fastener snaps into place.

#### 4. Battery Level Indicator

Make sure the battery is securely inserted in the flash. Check the battery level indication on the LCD panel to see the remaining battery level.

Battery Level Indicator	Indicates
4 bars	Full
3 bars	Medium
2 bars	Low
1 bars	Very low
Empty bar	Low battery. Please charge as soon as possible
Flashing	Battery is about to run out. The flash will no longer work. Please recharge the battery as soon as possible (within 10 days), the battery can then be used or stored for a long period.

### Power Management

Use ON/OFF Power Switch to power the flash unit on or off. Please turn off the power if the flash won't be used for a long period. When setting as a transmitter (TX) flash, the flash will turn the power off automatically after a certain period (approx. 90 seconds) of inactivity. Pressing the camera shutter halfway or pressing any flash button will wake up the flash unit. When setting as a receiver (RX) flash, it will enter sleep mode after a certain period (adjustable, 60 minutes by default) of idle use. Pressing any flash button will reactivate device.

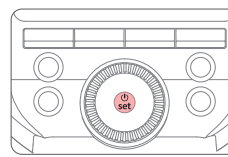

Press and hold the power button for 2s to turn the flash on/off.

### Power Management

Note: ① When used off the camera, it is recommended that you customize the function to disable "automatic power off".  
② Receiver Auto Power Off Timer is set to 60 minutes by default. A 30 minute timer can also be applied.

### Mount / Unmount flash

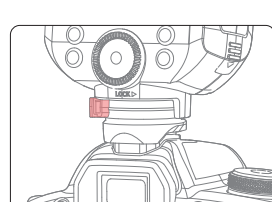

1. Mount the Camera Flash  
Turn the locking ring to the left to fully insert the camera's hot shoe.

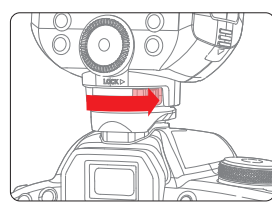

2. Secure the Camera Flash  
Rotate the locking ring to the right until secure.

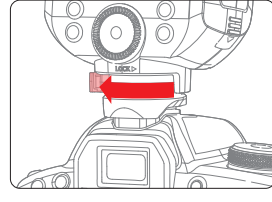

3. Unmount the Camera Flash.  
Press the button and rotate the hotshoe locking ring to the left to loosen.

### Flash Mode: i-TTL Autoflash

The flash had three flash modes: auto flash(i-TTL), manual flash(M), and stroboscopic flash (RPT). When used in i-TTL mode, the flash will use your camera's metering system to read the light exposure from the subject and automatically adjust flash output to get even exposure of the subject and background. It features i-TTL flash exposure compensation, high-speed sync, second-curtain shutter sync, etc.

\* Press <MODE> Mode Selection Button. The three flash modes will display on the LCD panel in a cycle.

### Flash Mode: i-TTL Autoflash

#### 1. i-TTL Mode

- Press <MODE> Mode Selection Button to enter i-TTL mode.
- ① Press the camera release button halfway to focus. The aperture will be displayed in the viewfinder.
  - ② A pre-flash is fired moments before the shutter is released, and the flash receives camera information for the main flash.

#### 2. FEC(Flash Exposure Compensation)

In FEC mode, the flash can adjust flash exposure compensation in 1/3-stop increments between ±3 stops. This feature is useful when the i-TTL system needs to be fine-tuned to accommodate the shooting environment.

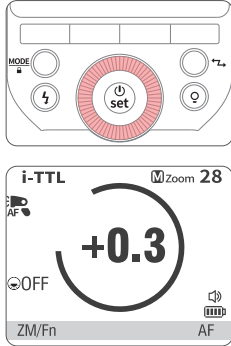

Set the flash exposure compensation amount.

- ① Turn the Select Dial to set the amount.
- ② "0.3" indicates 1/3 step, "0.7" indicates 2/3 step.
- ③ To cancel the flash exposure compensation, set the amount to "0.0".

#### 3. HSS: High Speed Sync

High Speed Sync (FP flash) enables the flash to synchronize with all camera shutter speeds. This is convenient when you want to use aperture priority for fill-flash portraits.

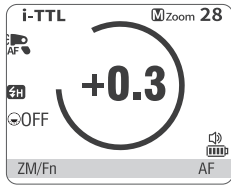

### Flash Mode: i-TTL Autoflash

#### Select High Speed Sync \* ② \*

- ① Set the Flash Sync Speed of your Nikon camera to 1/320s(Auto FP) or 1/250s(Auto FP). Half press the camera shutter, and the HSS symbol <HSS> will appear on the flash display to indicate that flash high speed sync is enabled.
- ② Rotate the camera dial to set shutter speed to 1/250s or higher.
- ③ Please ensure the FP high speed sync has been activated by checking the shutter speed on camera viewfinder. If the camera shutter speed is set at 1/250s or higher, then high speed sync has been successfully enabled.

\* If you have set the Flash Sync Speed to 1/320s(Auto FP) or 1/250s(Auto FP) on a Nikon camera, rotate the camera dial with the shutter speed configured at 1/250s or above, the <HSS> icon will appear on the flash screen.

\* With high-speed sync, the faster the shutter speed, the shorter the effective flash range.

\* If the Flash Sync Speed of your Nikon camera is set as OFF (Auto FP), then the <HSS> symbol won't appear on flash display when the camera shutter is half pressed.

\* RPT flash mode cannot be set in high-speed sync mode.

\* Over-temperature protection may be activated after 30 consecutive high-speed sync flashes.

#### 4. Second-Curtain Sync

With a slow shutter speed, you can create a trail of light following the subject. The flash fires right before the shutter closes.

\* Select REAR flash mode on your Nikon camera to enable rear-curtain flash sync.

### M: Manual Flash

The flash output is adjustable from 1/1 full power to 1/256th power in 1/10th stop increments. To obtain a correct flash exposure, use a hand-held flash meter to determine the required flash output.

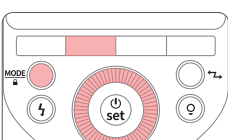

- ① Press <MODE> button so that <M> is displayed.

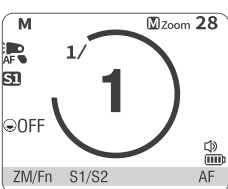

- ② Turn the Select Dial to set the flash output rating.

Press function button 2 to adjust the S1/S2 mode

\* S1 Optical control unit setting  
In M manual flash mode, the S1 function can be used and the flash unit can function as an optical secondary flash. In this mode, it will fire synchronously when the main flash fires, the same effect as that obtained by the use of radio triggers. This helps the photographer create multiple lighting effects.

\* S2 Optical control unit setting  
In M manual flash mode, the S2 function can be used and the flash unit can function as an optical S2 secondary flash. In this mode, it will ignore the pre-flash emitted by the TTL flash and will only fire in response to the second flash from the main unit.

Note: S1 and S2 optical triggering is only available in M manual flash mode.

### RPT: Stroboscopic Flash

The term stroboscopic flash relates to a rapid series of flashes being fired. It can be used to capture multiple images of a moving subject in a single photograph.

You can set the firing frequency (number of flashes per sec. expressed as Hz), the number of flashes, and the flash output.

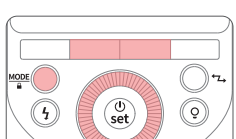

- ① Press the <MODE> button so that <RPT> displays.

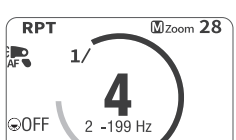

- ② Set the flash frequency and the number of flashes.
- ③ Press the Function Button 2 <Times> to select the number of flashes. Turn the Select Dial to set the value.
- ④ Press the Function Button 3 <Hz> to select the flash frequency. Turn the Select Dial to set the value.
- ⑤ Turn the adjustment knob to set the flash output power.

Calculating the Shutter Speed:

During a stroboscopic flash, the shutter remains open until the firing stops. Use the formula below to calculate the shutter speed setting in a single photograph.

$$\text{Number of Flashes} / \text{Flash Frequency} = \text{Shutter Speed}$$

For example, if the number of flashes is 10 and the firing frequency is 5 Hz, the shutter speed should be at least 2 seconds.

\* To avoid overheating and deterioration of the flash head, do not use the stroboscopic flash more than 10 times in succession. After 10 times, allow the camera flash to rest for at least 15 minutes. If you try to use the stroboscopic flash more than 10 times in succession, the flash may stop flashing automatically. This is to protect the flash head. Should this happen, please allow the camera to rest for 15 minutes.

\* Stroboscopic flash is most effective with a highly reflective subject against a dark background.

\* It is recommended to use a tripod and a remote control.

\* A flash output of 1/1 and 1/2 cannot be set for stroboscopic flash mode.

\* Stroboscopic flashes can be used with the "buLb" function.

\* If the flash count is displayed as --, the flash will fire continuously until the shutter release or the battery is exhausted. The number of flashes will be limited as shown in the table below.

### RPT: Stroboscopic Flash

#### Maximum number of strobe flashes

Flash Output	Hz	1	2	3	4	5	6-7	8-9
1/4		8	6	4	3	3	2	2
1/8		14	14	12	10	8	6	5
1/16		30	30	30	20	20	20	10
1/32		60	60	60	50	50	40	30
1/64		90	90	90	80	80	70	60
1/128		100	100	100	100	100	90	80
1/256		100	100	100	100	100	90	80

Flash Output	Hz	10	11	12-14	15-19	20-50	60-199
1/4		2	2	2	2	2	2
1/8		4	4	4	4	4	4
1/16		8	8	8	8	8	8
1/32		20	20	20	18	16	12
1/64		50	40	40	35	30	20
1/128		70	70	60	50	40	40
1/256		70	70	60	50	40	40

### Wireless Flash Shooting: Wireless (2.4G) Transmission

\* With creative radio control system, the speedlite supports S RX flash groups in i-TTL auto flash mode. Use the i-TTL auto flash to obtain multiple lighting effects.

\* Any group flash settings on the TX flash unit, whether in i-TTL auto flash, manual flash or multi flash mode, will all be transmitted to the corresponding RX flash units. Therefore, you will only need to change settings on the TX unit to control each RX flash group, without having to individually set the RX units one by one.

### Wireless Flash Shooting: Wireless (2.4G) Transmission

\* When the Z2-N is set as a TX flash unit, it supports operation in 4 flash modes: i-TTL/M/RPT/OFF.

Positioning and Operation Range (Example of wireless flash shooting):

#### Autoflash Shooting with One Receiver Unit

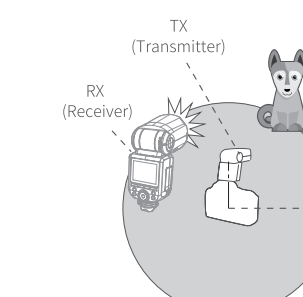

\* Use the supplied mini stand to position the Receiver unit.

\* Perform a test flash and test shot before shooting.

\* The transmission distance might be shorter depending on the conditions such as the positioning of the Receiver units, the surrounding environment and weather conditions.

#### Wireless Multiple Flash Shooting

You can split the RX unit into two or three groups and shoot i-TTL Auto Flash while changing the flash ratio (focus). In addition, each flash group (up to 5 groups) can be set and shot with different flash modes.

#### ① Auto flash shooting with two RX groups.

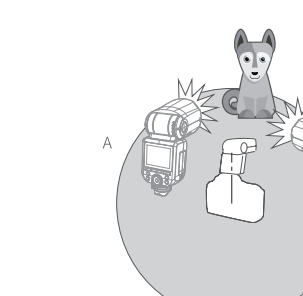

**Wireless Flash Shooting: Wireless (2.4G) Transmission**

② Auto flash Shooting with three RX groups

### 1. Wireless Settings

You can switch between normal flash and wireless flash. For normal flash, be sure to set wireless Settings to "off".

#### Transmitter (TX) Unit Setting

- Press the **<Z>** wireless setting button and turn the adjustment knob to select TX.
- Press the Setup button to confirm. The screen will display the symbols **<W>** and **<TX>**.

#### Receiver (RX) Unit Setting

- Press the **<Z>** wireless setting button and turn the adjustment knob to select RX.
- Press the Setup button to confirm. The screen will display the symbols **<W>** and **<RX>**.

**Wireless Flash Shooting: Wireless (2.4G) Transmission**

### 2. Flash Group Mode Selection

- Press function key 2 **<GR>** to select group M/A/B/C.
- Press function key 3 **<MODE>** again to toggle between TTL /M/-. Choose your preferred mode as the flash setting for the TX unit.
- Use the MODE button to switch to RPT mode.

### 3. Setting the communication channel

If there is more than one wireless flash system nearby, you can change the communication channel to prevent signal interference. Ensure that the channel of the transmitter and receiver units are matching.

- Long press function button 1 **<ZM/Fn>** to enter custom CH settings.
- In Custom CH settings screen, turn the Select Dial to choose a channel from 01 to 32.

\*After setting, press function button 1 to exit

**Wireless Flash Shooting: Wireless (2.4G) Transmission**

### 4. Wireless ID Settings

In addition to changing the wireless communication channel to avoid signal interference, you can also change the wireless ID to prevent interference. Set the channel and the wireless ID of the transmitter unit and the receiver unit to the same values. Go to C.Fn ID and choose wireless ID from 01 to 99. Select OFF to disable the wireless ID.

\*After setting, press function button 1 to exit.

### 5. Scan for a free, unused channel

To avoid the issue of interference by using the same channel(s) already in use by others, use this function: enter the C.Fn settings and find the SCAN option. When setting it to START, it will scan from 1% to 100%. The 10 spare channels will be displayed after the scan is completed.

\*After setting, press function button 1 to exit.

### 6. i-TTL: Automatic wireless flash photography

Note: The transmitter (TX) unit and the receiver (RX) unit must have the same wireless ID, channel and group before the flashes can be fired wirelessly.

Using Automatic Wireless Flash with a Single Receiver Unit.

- Press Function Button 2 **<GR>** to select the group, and then press Function Button 3 **<MODE>** to choose the TTL option.

**Wireless Flash Shooting: Wireless (2.4G) Transmission**

- Rotate knob to set exposure compensation for selected group.

RX Unit

- Transmitter Unit Setting  
Set the Z2-N flash mounted on camera as the TX unit. (Page 15) The M/A/B/C groups all support TTL.
- Receiver Unit Setting  
Set the Z2-N to be controlled wirelessly as a RX unit. (page 15) Choose from groups A/B/C/D/E.
- Receiver Unit Setting  
Set the TX unit and the RX unit to the same channel. (Page 16)
- Position the camera and flashes.  
Position the TX and the RX unit at close range as shown on Page 14.
- Check if the flash is ready.  
Check that the Transmitter flash ready indicator is lit.
- Check the flash operation.  
① Press the Transmitter unit's Test Button **<Z>**.  
② The Receiver unit should then flash. If it doesn't, check the receiver is placed within the operating range.

### Using Automatic Wireless Flash with Multiple Receiver (RX) Units

When a larger flash output is required, you can increase the number of RX units and flash them as a single flash.

To add receiver (RX) units, use the same steps as setting "automatic wireless flash with a single Receiver unit". Any flash group can be set (A/B/C/D/E).

**Wireless Flash Shooting: Wireless (2.4G) Transmission**

When the number of RX units is increased or the TX flash is set to ON, automatic control ensures that all flashes fire at the same flash output so that the total flash output meets the standard exposure.

- \* If the auto power off of the RX unit has kicked in, press the test button on the TX unit to trigger a flash button enables the RX unit. Please note that the flash cannot be tested during the camera's metering time.
- \* You can change the delay setting for when the RX flash unit automatically enters sleep mode (C.Fn-RX STBY/Page 24).

### Using a fully automatic wireless flash

The flash exposure compensation (FEC) and other settings set on the TX unit are also set automatically in the RX unit. Operation of the RX unit is not required. The following settings can be used for shooting with no line flash in the same way as for normal flash shooting.

- \* Flash Exposure Compensation (Page 09)

### About Transmitter Unit

Two or more TX units can be used. By configuring multiple cameras with TX units, you can change the cameras used for shooting while maintaining the same lighting (RX units).

### 7. M: Manual Wireless Flash Shooting

Shooting with manual flash with no line (multi-flash) allows you to set different flash outputs for each RX unit (flash group) for shooting. All parameters need to be set on the TX control unit.

- Press Function Button 2 **<GR>** to select the group, and then press Function Button 3 **<MODE>** to choose the M option.

**Wireless Flash Shooting: Wireless (2.4G) Transmission**

- Rotate the adjustment knob to adjust the flash output for the flash group, and press the Setting button to confirm.
- Taking pictures. Each group fired at the set flash ratio.

### Setting <M> Flash Mode

You can directly operate the Receiver unit to manually set the manual flash or stroboscopic flash.

- Setting the Receiver unit.
- Setting flash mode to **<M>**.
- Press **<MODE>** button so that **<M>** displays.
- Set the manual flash output.

### 8. RPT: Wireless Flash Shooting with Manual Flash

To set the **<RPT>** strobe mode.

- In the main control screen mode, press the **<MODE>** mode selection button to display **<RPT>**.
- Set the strobe flash setting in the main control screen mode.

In receiver unit mode, press the **<MODE>** button to display **<RPT>**.

**Troubleshooting: 2.4G wireless flash misfiring**

- Interference of the 2.4G signal resulting from external factors (such as wireless hub, 2.4G Wi-Fi routing, Bluetooth equipment, etc.)  
→ Please adjust the channel CH setting of the transmitter (+10 is recommended) to find a channel without interference, or turn off other 2.4G devices in close proximity whilst working.
- Please ensure that the flash is fully recycled, the flash ready indicator is on and that the overhear protection feature hasn't been triggered.  
→ Please lower the flash setting by changing to manual mode (M) if the device is in i-TTL mode, you need to fire a preflash.
- Please check whether the flash detector and the receiving device are running low on power  
→ Please replace the batteries (1.5V disposable alkaline batteries are recommended for the flash receiver battery)

### Other Applications

#### 1. Sync Triggering

The Sync Cord Jack is a Ø2.5mm connector. Insert a trigger plug here and the flash will be fired in sync with the camera shutter.

#### 2. Auto Focus Assist Beam

In low-brightness or low-contrast shooting situations, the flash's built-in autofocus assist lamp turns on to make autofocus easier. When focusing is difficult, the red autofocus assist light comes on.

To turn off the autofocus function, set "AF" to "OFF" in C.Fn.

- \* If the user finds that the assisted focus light is not on when using it, it is because the camera is already accurately focused.

Position	Operating range
Center	0.6-10m / 2.0-32.8 feet
Periphery	0.6-5m / 2.0-16.4 feet

#### 3. TCM - One key switching i-TTL/M mode:

Utilize i-TTL auto mode for quick metering while retaining metering data, and seamlessly switch to manual mode for precise adjustments.

Toggle the TCM button to 'M' for one-touch switching.

**Other Applications**

#### 4. Bounce Flash

By pointing the flash head toward a wall or ceiling, the flash will bounce off the surface before illuminating the subject. This can soften shadows behind the subject for a more natural-looking shot. This is commonly known as a 'bounce flash'.

Position the flash head to set the bounce direction.

- \* If the wall or ceiling is too far away, the bounced flash might be too weak and result in underexposure
- \* The wall or ceiling should be a plain, white color for high reflectance. If the bounce surface isn't white it will result in "off color" photos.

#### 5. ZOOM: Set the flash coverage

The flash coverage can be set automatically or manually. It can be set to match the lens focal length from 28mm to 105mm. In auto zoom, the focal length changes with the camera's zoom lens to provide the best flash effect.

- Turn the Select Dial to change the flash coverage.
- If **A** is displayed, the flash coverage will be set automatically.

- \* If you set the flash coverage manually, make sure it covers the lens focal length so that the picture will not have a dark periphery.

**Other Applications**

### 6. Modeling Lamp

Switching on the Modeling Lamp

- Short press the modeling lamp button **<Q>**.
- Rotate the adjustment knob to set the modeling lamp brightness level from 01 to 10.
- Short press the **<Q>** button to confirm the selection.

\* Long press the styling light button **<Q>**, then rotate the adjustment knob to switch between styling lights **<Q>** and styling lights **<Q>**.

### 7. Modeling Flash

If your camera has a depth-of-field preview button, pressing it activates a 1-second continuous flash, known as modeling flash. This feature helps you observe the effect of the light and shadow on your subject and evaluate the illumination balance, whether you're using wireless or standard flash.

- \* Avoid triggering the modeling flash more than 10 times in quick succession. If you've performed 10 consecutive modeling flashes, please allow the flash to cool down for at least 10 minutes to prevent overheating or damage to the flash head.

### C.Fn: Setting Custom Functions

- Long press the function button 1 **<ZM/Fn>** to access the customized menu.
- Rotate the adjustment knob to choose a parameter.
- Press the Setting button to enter the parameter adjustment mode.
- Rotate the adjustment knob to modify the parameter.
- Press the Setting button again to confirm the parameter.
- Short press function button 1 to exit.

**C.Fn: Setting Custom Functions**

Use the Customize function to complete settings according to the following chart.

Custom Function Symbols	Function	Setting No.	Set-Up and Instructions
AF	AF-assist beam	ON OFF	on off
STBY	Auto sleep setting	OFF 60min 60min	off 60min 60min
RX STBY	Receiver auto power off timer	30min OFF	30min off
BEEP	Beeper	ON OFF	on off
SCAN	Scan for idle channels	START	Start search for idle channel
CH	Channel setting	01-32 OFF	Choose a channel from 01-32 off
ID	Wireless ID	01-99 1-100M 0-10M	Choose any figure from 01-99 1-100M flash 0-10M flash
LIGHT MODE	Modeling Lamp	☺ ☹	Top Modeling Lamp Bottom Modeling Lamp
MODEL	Modeling Lamp	CONT INTER	Modeling Light Continuous Modeling light interrupted

**Protection Function**

#### 1. Over-Temperature Protection

- To prevent the flash head from deteriorating and overheating, it is recommended not to fire more than 30 continuous flashes in fast succession at 1/1 full power. After 30 continuous flashes, pause the use of the flash for at least 10 minutes.
- If you fire more than 30 continuous flashes and then fire more flashes in short intervals, the inner over-temperature protection function may be activated. The recycling time will be longer (over 10s). If this occurs, the use of the device should be paused for at least 10 minutes for the flash unit to operate as normal.

Number of flashes that will activate over-temperature protection:

Power	Number of Flashes
1/1	30
1/2 +0.7	40
1/2 +0.3	50
1/2	60
1/4(+0.3,+0.7)	100
1/8(+0.3,+0.7)	200
1/16(+0.3,+0.7)	300
1/32(+0.3,+0.7)	500
1/64(+0.3,+0.7)	1000
1/128(+0.3,+0.7)	
1/256(+0.3,+0.7)	

#### 2. Other Safety Functions

\* The system provides real-time protection to secure the device and your safety. The following lists prompts for your reference:

Prompts on LCD Panel	Indicates
EI	A fault has developed with the flash's recycle system so that the flash cannot fire. Please restart the flash unit. If the problem still exists, please send this product to a maintenance center.
HOT	The flash will disable when the temperature inside the unit is too high in which case you should stop using the flash for 10 minutes.

**Technical Data**

Model	Z2-N
Compatible Cameras	Nikon Digital Single Lens Reflex Camera (i-TTL auto flash)
Power (1/1 output)	76Ws
Flash Coverage	28-105 mm
	Auto zoom - Manual zoom
Flash Duration	Swinging/tilting flash head (bounce flash): 0 to 330° horizontally and -7° to 120° vertically
	1/180 to 1/20000 seconds
Exposure Control	
Exposure control system	i-TTL autofocus and manual flash
Flash exposure compensation (FEC)	Manual, FEB: ±3 stops in 1/3 stop increments (Manual FEC and FEB can be combined.)
Sync mode	High-speed sync (up to 1/8000 seconds), first-curtain sync, and second-curtain sync
RPT flash	Autonomy (up to 100 times, 199Hz)
Wireless flash (radio 2.4G transmission)	
Wireless flash function	Transmitter, Receiver, OFF
Transmitter groups	M, A, B, C
Controlable Receiver groups	A, B, C, D, E (E group can be controlled by QPRO series flash trigger available on Neewer.com)
Transmission range (approx.)	100m
Channels	32 Groups: 01-32
ID	01-99
Frequency Range	2412.75MHz-2464.25MHz
Maximum radio-frequency power	5.30dBm
Modeling Flash	Using the camera's depth-of-field preview button
Auto Focus Assist Beam	
Effective range (approx.)	Center: 0.6-10m / Periphery: 0.6-5m
Power source	
Built-in Li-ion battery	7.2V/3000mAh Li-ion battery
Recycle time	Approx. 1.5 seconds. Red LED indicator will light up when the flash is ready.
Number of flash in full power	Approx. 600
Energy-saving	Auto Power off after approx. 90 seconds of idle operation, (60 minutes if set as Receiver)
Sync Triggering Mode	Hotshoe, 2.5mm sync line
Modeling Lamp	
Power	2W
Color Temperature	3300K±200K
Dimensions	
Volume	76*76*206 mm
Net weight without battery	460g
Weight with battery	580g
Operating Temperature	0°C - 40°C

**Troubleshooting**

If you experience a problem with the device, please refer to this Troubleshooting Guide.

#### 1. The Camera Flash does not fire

- The camera flash is not attached securely to the camera.  
→ Attach the hot shoe base mount of the flash securely to the camera.
- The electrical contacts of the camera flash and camera are dirty.  
→ Clean the contacts.

#### 2. Auto power off

- After 90 seconds of idle operation, auto power off will have activated if the flash is set as Transmitter (Master).  
→ Press the shutter button halfway or press any flash button to wake up.
- After 60 minutes (or 30 minutes) of idle operation, the flash unit will enter sleep mode if it is set as Receiver (Slave).  
→ Press any flash button to wake up.

#### 3. Auto zoom does not work.

The camera flash is not attached securely to the camera.  
→ Attach the camera flash's mounting base to the camera.

#### 4. The flash exposure is underexposed or overexposed.

- There was a highly reflective object (e.g. glass window) in the picture.  
→ Use FE lock (FEL).
- You used high-speed sync.  
→ With high-speed sync, the effective flash range will be shorter. Make sure the subject is within the effective flash range displayed.
- Use Manual Flash mode.  
→ Set the flash mode to i-TTL or modify the flash output.

#### 5. Photos have dark corners or only parts of the target subject are illuminated.

The focal length of lens exceeds the flash coverage.  
→ Check the focal length that has been set. This flash unit has the flash coverage between 28 and 105mm, which fits medium-format cameras.

**Firmware upgrade**

The firmware of this product can be upgraded through the USB port. The latest software announcements and instructions will be published on the official website.

- \* This product does not come with a USB cable for the firmware upgrade. Please purchase separately. The USB port of this product is a Type-C port. Please use only a USB Type-C cable.
- \* Upgrading the firmware requires Neewer Firmware software support. Please download and install "Neewer Firmware Update", and then select the corresponding firmware file before updating.
- \* As the product is undergoing a firmware upgrade, please refer to the latest electronic version of the manual.

### Restore factory settings

- Press and hold both Function buttons 2 and 3 simultaneously.
- "RESET" will appear on the screen to indicate that the factory settings have been restored.

### Compatible Cameras

This camera is compatible with the following models of Nikon digital single mirror reflex camera series:

D4, D5, D60, D70S, D90, D100, D200, D300S, D300, D500, D610, D700, D750, D780, D800, D810, D850, D3100, D3200, D3300, D3400, D3500, D5000, D5100, D5200, D5300, D5600, D7000, D7100, D7200, D7500, Z5, Z6, Z6ii, Z30, Z9, Z8, Z7ii, Z7, Z50

Note: This table only lists the camera models that have been tested at present, and does not cover all Nikon series cameras. Other camera models can be tested by users.